



TDT SERIES

HIGH PERFORMANCE 3-PHASE, 3-WIRE FILTERS

COMPONENTS

PART NO.	ΣCx (uF)	ΣCy (uF)	L (mH)	R (M Ω)	R1 (M Ω)
08TDT2	1.6	0.17	7.6	2.0	-
16TDT2	3.4		5.2	1.5	1.1
25TDT2	4.4	2.2			
36TDT2		1.3			
50TDT2	2.0	0.8			

INTRODUCTIONS

1. Applications: Electric equipment, UPS, machine tool, copy machine, automation equipment, robot, AC motor drive
2. Voltage rating: 480VAC
3. Operating frequency: 50/60Hz

MINIMUM INSERTION LOSS IN dB

COMMON MODE (L-G) IN 50 OHM SYSTEM									
PART NO.	FREQUENCY-MHz								
	.01	.05	.10	.15	.50	1.0	5.0	10	30
08TDT2	20	30	40	50	65	65	55	50	50
16TDT2	15	25	35	45	70	65	55	50	50
25TDT2	15	25	35	40	50	50	50	40	30
36TDT2	10	35	50	50	60	60	50	40	55
50TDT2	5	30	50	50	50	50	50	50	50
DIFFERENTIAL MODE (L-L) IN 50 OHM SYSTEM									
08TDT2	10	10	20	50	65	65	55	50	50
16TDT2	10	10	40	50	70	65	55	50	50
25TDT2	10	10	40	45	50	50	50	40	30
36TDT2	10	20	40	50	60	60	50	45	45
50TDT2	5	20	40	45	50	50	50	50	50

ELECTRICAL SCHEMATIC

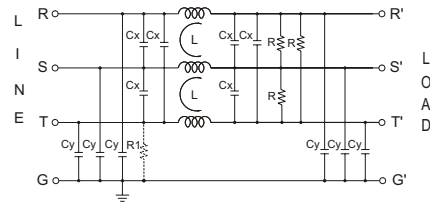

SERIES DIMENSIONS

PART NO.	DIMENSIONS IN INCHES/mm							
	A	B	C	D	E	F	G	H
08TDT2	7.165 182.0	3.425 87.0	2.40 61.0	4.606 117.0	4.528 115.0	3.937 100.0	8.898 226.0	—
16TDT2	7.953 202.0	4.803 122.0	2.598 66.0	5.984 152.0		5.354 136.0	9.646 245.0	
25TDT2					5.354 136.0	9.646 245.0		
36TDT2							5.354 136.0	
50TDT2					5.354 136.0	9.646 245.0		

MECHANICAL CONSTRUCTION

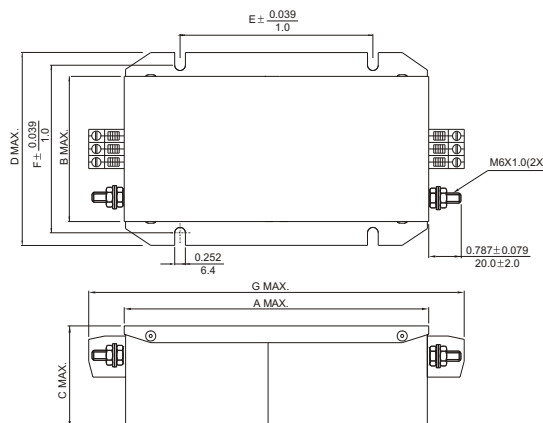
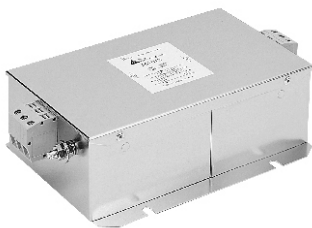

THREE-PHASE FILTERS